

**TECHNICAL MANUAL**

**OPERATOR'S AND UNIT MAINTENANCE MANUAL**

**(INCLUDING REPAIR PARTS AND SPECIAL TOOLS LIST)**

**FOR**

**81MM MORTAR TRAINING DEVICE:**

**81MM SABOT (INERT) M1**

**AND**

**22MM SUB-CALIBER PRACTICE CARTRIDGE**

**M744, M745, M746, AND M747**

**Approved for public release; distribution is unlimited.**

---

**HEADQUARTERS, DEPARTMENT OF THE ARMY**

**SEPTEMBER1990**

INSERT LATEST CHANGED PAGES.  
DESTROY SUPERSEDED PAGES.

**LIST OF EFFECTIVE PAGES**

**NOTE**

The portion of the text affected by the changes is indicated by a vertical line in the outer margins of the page. Changes to illustrations are indicated by a vertical line adjacent to the identification number.

**TOTAL NUMBER OF PAGES IN THIS PUBLICATION IS 52  
CONSISTING OF THE FOLLOWING:**

<i>Page No.</i>	<i>Change No.</i>	<i>Page No.</i>	<i>Change No.</i>
Cover	0		
Inside cover	0		
A	0		
i and ii	0		
1-1 thru 1-5	0		
1-6 blank	0		
1-7 thru 1-15	0		
1-16 blank	0		
2-1 thru 2-14	0		
3-1 and 3-2	0		
4-1	0		
4-2 blank	0		
A-1 thru A-3	0		
A-4 blank	0		
B-1 and B-2	0		
C-1	0		
C-2 blank	0		
D-1 thru D-3	0		
D-4 blank	0		
E-1	0		
E-2 blank	0		
Authentication page	0		

Technical Manual )  
 )  
 No. 9-1315-249-12&P )

HEADQUARTERS  
 DEPARTMENT OF THE ARMY  
 Washington, DC, 1 September 1990

Operator's and Unit Maintenance Manual  
 (Including Repair Parts and Special Tools List)  
 FOR  
 81MM MORTAR TRAINING DEVICE:  
 81MM SABOT (INERT) M1  
 AND  
 22MM SUB-CALIBER PRACTICE CARTRIDGE  
 M744, M745, M746, AND M747

**REPORTING OF ERRORS**

You can help improve this manual. If you find any mistakes or if you know of a way to improve the procedures, please let us know. Mail your letter, DA Form 2028 (Recommended Changes to Publications and Blank Forms) to Commander, U.S. Army Armament, Munitions and Chemical Command, ATTN: AMSMC-MAY-T(D), Picatinny Arsenal, NJ 07806-5000. A reply will be furnished directly to you.

			Paragraph	Page
CHAPTER	1.	INTRODUCTION		
Section	I.	General		
		Scope .....	1-1	1-1
		Forms, records, and reports.....	1-2	1-1
	II.	Description and Data		
		Description .....	1-3	1-1
		Data .....	1-4	1-10
	III.	Functioning		
		Sabot loaded with practice round .....	1-5	1-11
		22mm practice cartridge .....	1-6	1-14
CHAPTER	2.	OPERATING INSTRUCTIONS		
Section	I.	Safety Precautions		
		General .....	2-1	2-1
		Safety area.....	2-2	2-1
		Firing safety .....	2-3	2-3
		Duds.....	2-4	2-5
	II.	Operating Procedures		
		Preparation for firing .....	2-5	2-5
		Firing .....	2-6	2-12
		During firing .....	2-7	2-14
		Cancellation of firing .....	2-8	2-14
		Operation under extreme weather conditions .....	2-9	2-14

\*This manual supersedes TM 9-1315-249-12&P, 30 April 1975, including all changes.

		Paragraph	Page
CHAPTER	3.	OPERATOR MAINTENANCE	
		Prior to firing .....	3-1 3-1
		During firing.....	3-2 3-1
		After firing .....	3-3 3-2
CHAPTER	4.	UNIT MAINTENANCE	
		General .....	4-1 4-1
		Sabot .....	4-2 4-1
		22mm sub-caliber practice cartridge .....	4-3 4-1
APPENDIX	A.	REFERENCES.....	A-1
	B.	MAINTENANCE ALLOCATION CHART .....	B-1
	C.	BASIC ISSUE ITEMS LIST (not applicable) .....	C-1
	D.	REPAIR PARTS AND SPECIAL TOOLS LIST .....	D-1
	E.	CONSUMABLE MAINTENANCE SUPPLIES AND MATERIALS.....	E-1

**LIST OF ILLUSTRATIONS**

Figure	Title	Page
1-1	81mm Sabot, M1 .....	1-2
1-2	22mm practice cartridge, M744, M745, M746, M747 .....	1-3
1-3	81mm Sabot cross section showing 22mm cartridge in loaded position .....	1-4
1-4	81mm Sabot, MI-flange nut assembly .....	1-5
1-5	Sabot packing box .....	1-7
1-6	22mm cartridge cross section .....	1-8
1-7	Cartridge packing box .....	1-9
1-8	Firing of mortar training device and cartridge .....	1-12
1-9	Cartridge cross section .....	1-13
1-10	Diagram of Sabot and 22mm cartridge, firing to impact .....	1-14
1-11	Optical and acoustical observation of target strikes .....	1-15
2-1	Recommended safety zone .....	2-2
2-2	Misfire removal procedure .....	2-4
2-3	Removal of flange nut .....	2-6
2-4	Insertion of cartridge .....	2-7
2-5	Removal of safety cap .....	2-8
2-6	Replacement of flange nut.....	2-9
2-7	Removal of fired cartridge .....	2-11
2-8	Firing table for 81mm Sabot, M1, using 22mm practice cartridge .....	2-13
3-1	Cleaning staff assembly, cleaning wick and brushes .....	3-1

## CHAPTER 1

### INTRODUCTION

---

#### Section I. GENERAL

##### 1-1. Scope

This publication provides operator and unit personnel with instructions for maintenance and use of the training device for 81mm Mortars (all models); 81mm Sabot (INERT), M1; and 22mm sub-caliber practice cartridge, M744, M745, M746 and M747.

##### 1-2. Forms, Records, and Reports

a. General. Maintenance forms, records, and reports which are to be used by maintenance personnel at all levels are listed in and prescribed by DA PAM 738-750.

b. Field Reports of Accidents. Accidents involving injury to personnel or damage to materiel are reported on DA Form 285 in accordance with instructions in AR 385-40.

c. Report of Damaged or Improper Shipment. Damaged or improper shipments will be reported immediately using SF Form 364, Report of Discrepancy (ROD), AR 735-11-2 and/or SF 361, Discrepancy in Shipment Report, and AR 55-38.

d. Fire Reports. A fire report will be prepared on all fires, or explosions followed by fires, which result in injury, loss of life, or property damage (repair or replacement cost of \$100 or more) at all DA installations. Property includes Army equipment, materials, structures, plants, systems, timber or grassland or other property. Motor vehicles or aircraft damaged while in use are exempted from this report. For further information, refer to AR 420-90. Reports of fire, or explosion followed by fire, involving ammunition or explosives are made in addition to the reports specified in AR 385-40.

#### Section II. DESCRIPTION AND DATA 1-3. Description

a. General. The 81mm Sabot (INERT) M1 (fig. 1-1) is designed to fire a 22mm subcaliber practice cartridge M744, M745, M746 or M747 (charges 1, 2, 3, or 4, respectively) (fig. 1-2) as training device in all model 81mm mortars. The Sabot with 22mm sub-caliber practice cartridge provides realistic mortar firing training at distances which correspond to range fire distances in the ratio of 1 to 10. The subcaliber device can be fired using standard mortar and sighting and fire control equipment and a special firing table (fig. 2-8) in the same manner as standard service mortar ammunition.

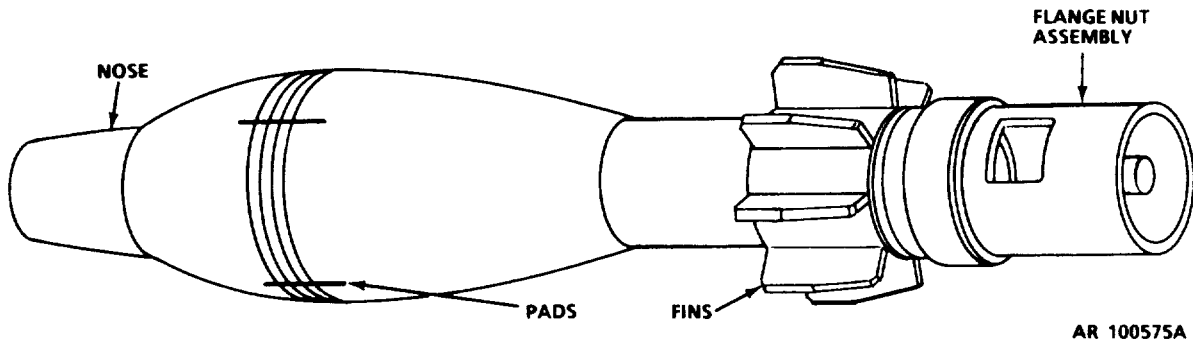
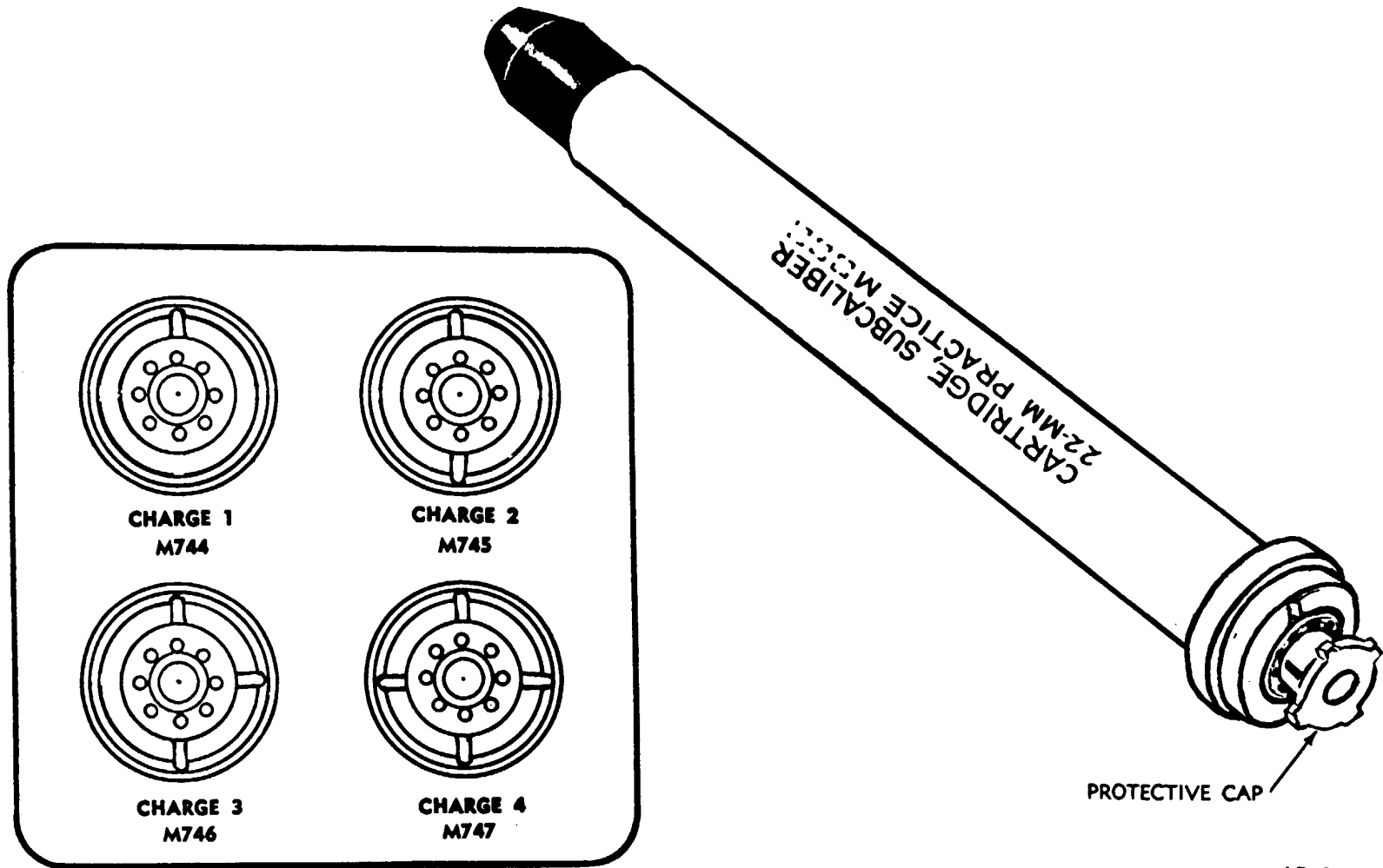

Figure 1-1. 81 mm Sabot, M1.



AR 100576-A

Figure 1-2. 22-mm practice cartridge, M744, M745, M746, M747.

**WARNING**

**USE TYPE IV FLANGE NUT ASSEMBLIES (FIG. 1-4) ONLY. ALL OTHER TYPES MUST BE REPLACED WITH THE LATEST FLANGE NUT ASSEMBLY (NSN 1315-01-163-5428).**

b. 81mm Sabot (INERT) M1. The Sabot (aluminum alloy body) has the bore riding dimensions and configuration of an 81mm mortar cartridge. It contains an insert 22mm barrel (not rifled) placed longitudinally to receive the 22mm sub-caliber cartridge which is loaded in the magazine just prior to firing (fig. 1-3). A flange nut assembly (fig. 1-4) retains the 22mm sub-caliber cartridge in the Sabot, initiates the percussion primer and deflects the ejection charge gases (to prevent erosion of the mortar basecap). The shaft of the Sabot (fig. 1-1) has fins (similar to fins of the service mortar cartridge) and guide pads to guide the Sabot as it travels up the mortar tube when fired. The nose of the Sabot is solid brass to protect the assembly on impact. On firing, the loaded Sabot is ejected from the mortar barrel. The Sabot hits the ground within 4 yards in front of the mortar while the 22mm practice cartridge flies on to its target. When not loaded with a 22mm practice cartridge the Sabot (INERT) may be used as a dummy round. The Sabot is rugged and can be reloaded and fired again (up to 1,000 times) for training purposes. It is stored (INERT) in a packing box containing 3 rounds (fig. 1-5).

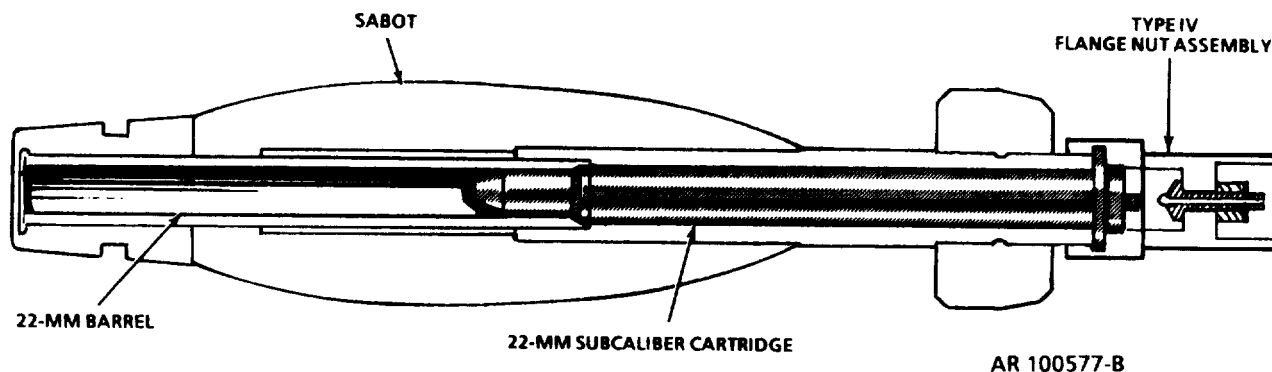

**Figure 1-3. 81 mm Sabot cross section showing 22mm cartridge in loaded position.**



81MM: SABOT, M1 - FLANGE NUT ASSEMBLY  
PART # 9311189

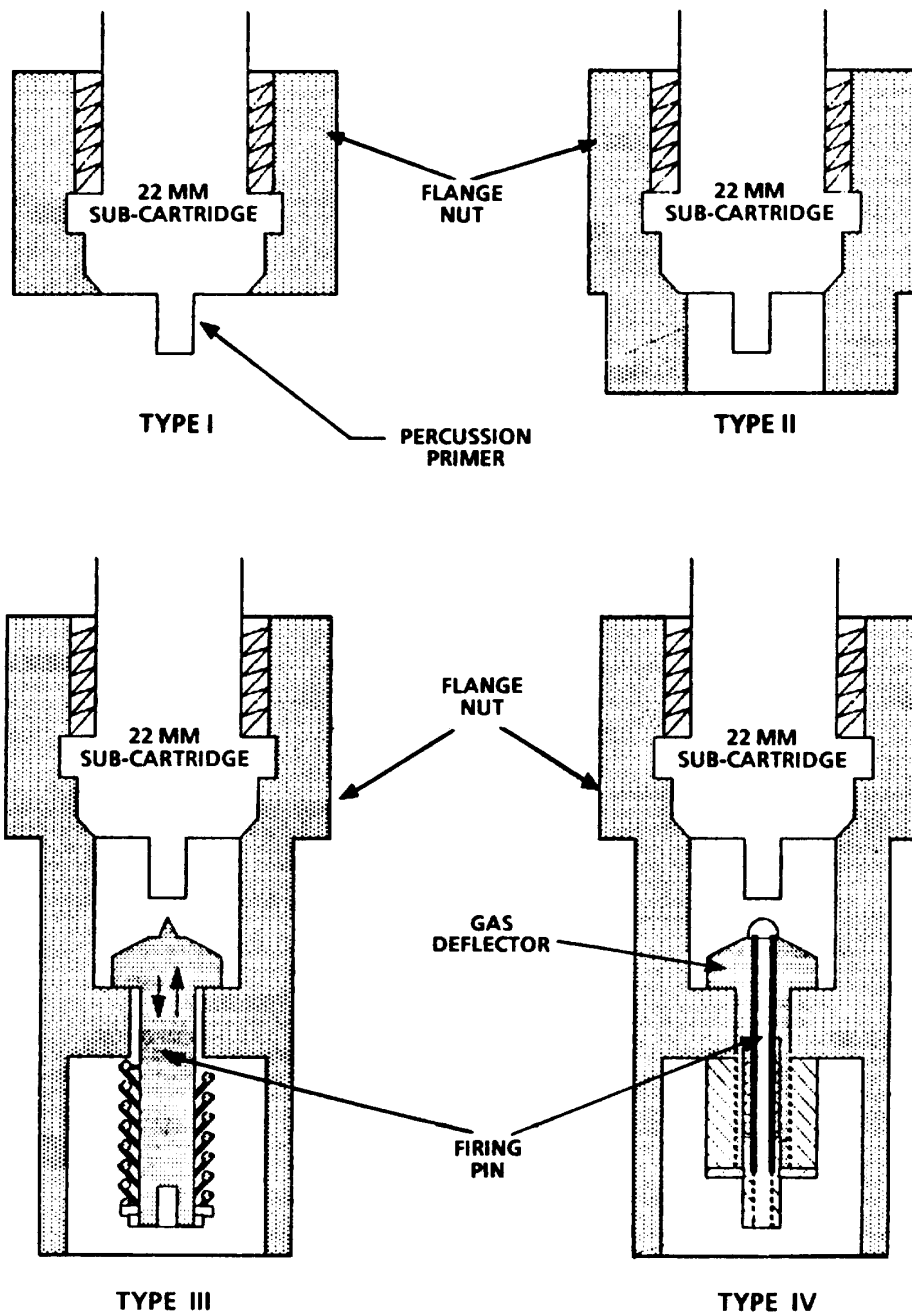

NSN: 1315-01-163-5428

U  
AR 3768

Figure 1-4. 81mm Sabot, M1-flange nut assembly.

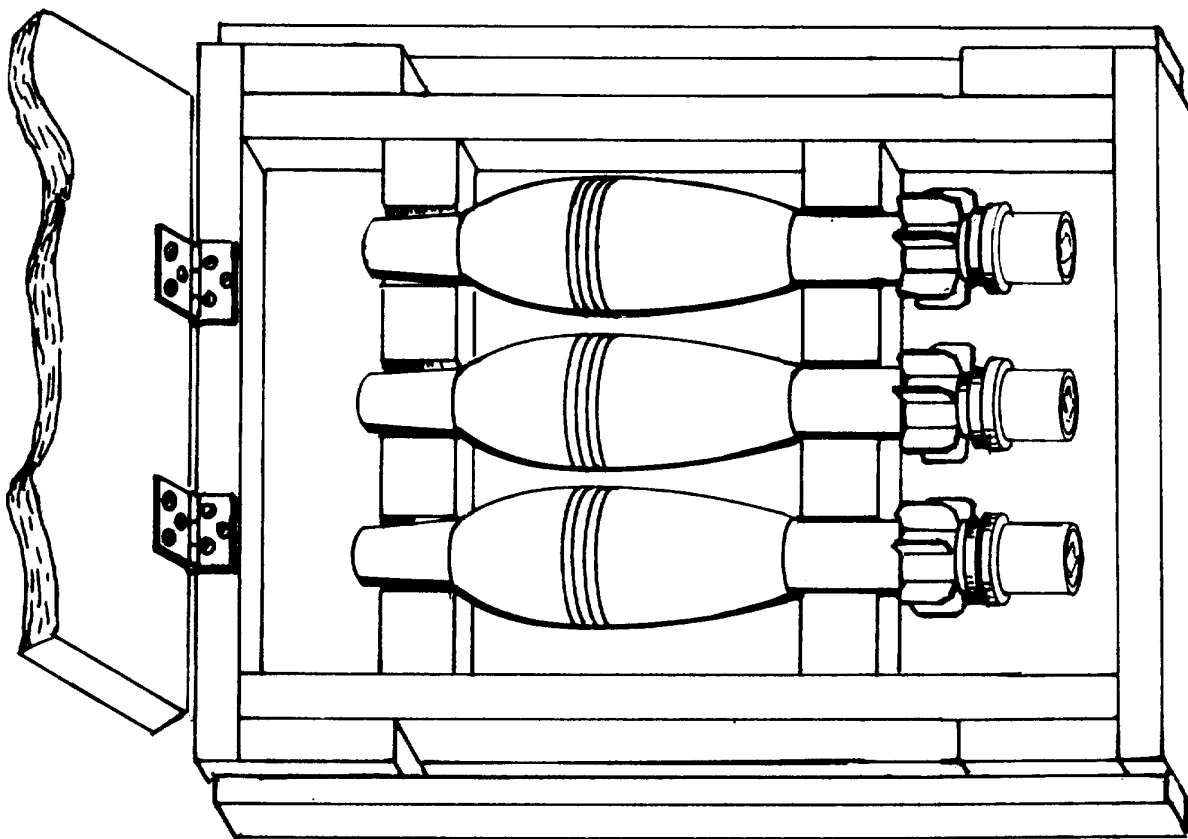

AR 100578-B

**Figure 1-5. Sabot packing box.**

c. 22mm Sub-caliber Practice Cartridge, M744 (charge 1), M745 (charge 2), M746 (charge 3), M747 (charge 4). The cartridge (fig. 1-6) consists of the projectile with stabilizer fins and cartridge case (divided chambers). The projectile has a steel body flattened at the tip. The wingshaft assembly, press-fit into the projectile body, contains the stabilizer fins (spring steel wrapped around the shaft) to stabilize flight. The wingshaft assembly also serves to seal the base of the projectile body. The projectile body (fig. 1-9) contains the impact fuze and smoke signal charge. The propelling and ejection charges are contained in two separate chambers located in the jet-housing assembly, which is threaded into the base of the cartridge case. A flash tube hole between the chambers permits ignition of the propelling charge by the ejection charge. The cartridges are manufactured in a variety of four propellant charges. Each charge can be identified by notches on the jet screw assembly (fig. 1-2). One notch designates M744 (charge 1), two notches designate M745 (charge 2), etc. Cartridges are packed 100 per Tri Wall Test Board (#1100) Box (Spec PPP-B-640) with each cartridge in its own molded polystyrene compartment (fig. 1-7).

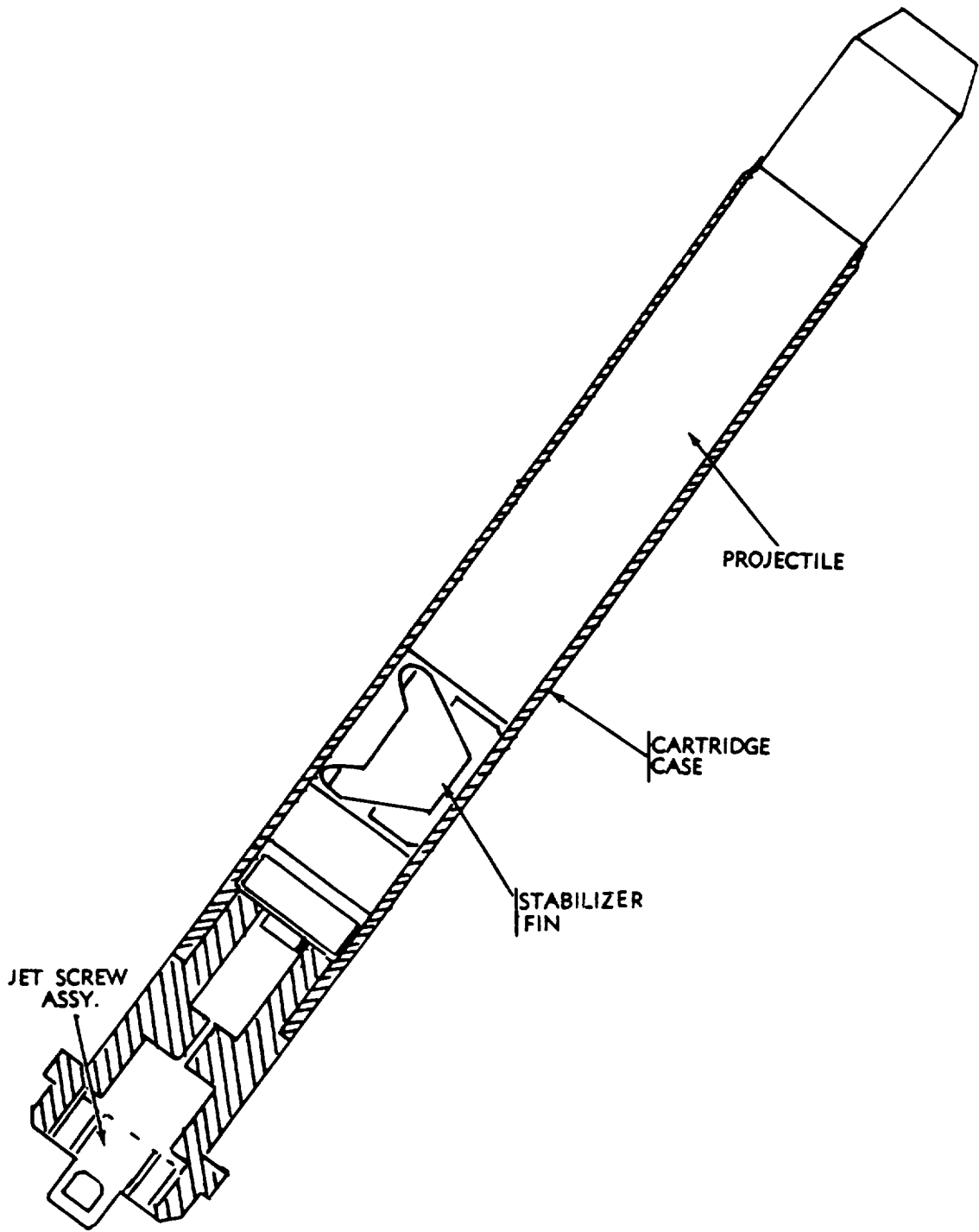

AR 100579

Figure 1-6. 22mm cartridge cross section.

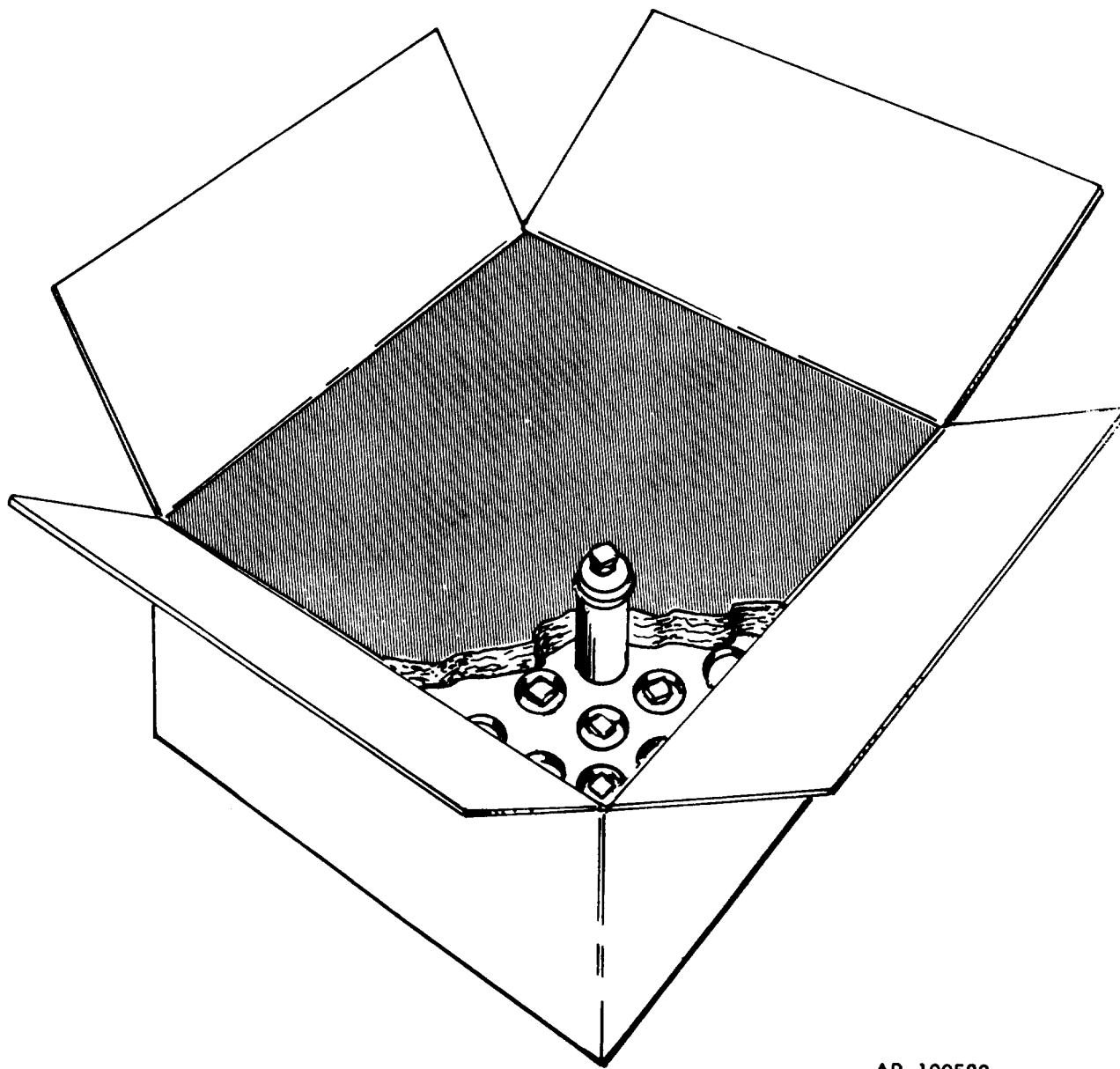

AR 100580

Figure 1-7. Cartridge packing box.

1-4. Data

a. Characteristics.

(1) 81mm Sabot.

Length(overall) .....	16.150 in	(410.2mm)
Weight .....	8.5 lb	(3850g)
Box, packing dimensions .....	25-1/8 X 13-11/16 X 6-7/16	
in		
Box, packing gross weight .....	54 lb	(24,462 g)

(2) 22mm sub-caliber practice cartridge.

Length with protective cap (overall) .....	9.697 in	(246.3mm)
Length without protective cap (overall) .....	9.618 in	(244.3mm)
Weight .....	1.097 lb	(497 g)
Weight of projectile .....	0.662 lb	(300 g)
Box, packing dimensions .....	20 x 20 x 12 in	
Box, packing gross weight .....	120 lb	(54,331 g)

(3) Ejection charge.

Weight - nominal		
Charge 1 .....	0.05 oz nominal	(1.5 g)
Charge 2 .....	0.05 oz nominal	(1.5 g)
Charge 3 .....	0.06 oz nominal	(1.7 g)
Charge 4 .....	0.06 oz nominal	(1.7 g)
Composition -		
Nitrocellulose .....	58.2%	
Nitrogen-content of the Nitrocellulose .....	12.7-12.9%	
Nitroglycerin.....	40%	
Diphenil Amine .....	1.0%	
Vaseline .....	0.3%	

(4) Propelling charge.

Weight -		
Charge 1 .....	0.03 oz nominal	(0.8 g) nominal
Charge 2 .....	0.04 oz nominal	(1.1 g) nominal
Charge 3 .....	0.06 oz nominal	(1.6 g) nominal
Charge 4 .....	0.08 oz nominal	(2.1 g) nominal
Composition -		
Potassium Nitrate.....	75 ± 1.5%	

Sulphur .....	10 ± 0.5%
Charcoal .....	15 ± 1%

(5) Smoke charge.

Weight .....	0.25 oz nominal (7g) nominal
Composition -	
Aluminum Powder .....	36%
Perchlorate of Potassium .....	36%
Cadmium .....	28%

(6) Percussion cap (identical in jet screw assembly and percussion piece assembly).

Composition -	
Tetrazene .....	6 ± 2%
Chlorate of Potassium.....	52 ± 5%
Antimony Sulphide	} 42 ± 5%
Calcium Silicide .....	
Glass	

b. Ballistics.

(1) Muzzle velocity.

Charge 1 .....	148 ft/sec	(45 meter/sec)
Charge 2 .....	164 ft/sec	(50 meter/sec)
Charge 3 .....	197 ft/sec	(60 meter/sec)
Charge 4 .....	230 ft/sec	(70 meter/sec)

(2) Maximum effective range.

Charge 1 .....	639 ft	(195 meter)
Charge 2 .....	770 ft	(235 meter)
Charge 3 .....	1082 ft	(330 meter)
Charge 4 .....	1427 ft	(435 meter)

c. Temperature Limits.

- (1) Firing. -40° F to + 120° F.
- (2) Storage. -40°F to + 120°F.

d. DOT Classification. Cartridges: Practice Ammunition Explosive C.

- e. Quantity Distance. Class 1.
- f. Storage Compatibility. Group B, E or N.
- g. Item Description and Supply Data.

Description	National Stock No.	Part No.	Federal Supply Code for Manufacturing
SABOT, 81MM, PRACTICE: M1 (inert)	1315-00-328-5666	9287906	19203
CARTRIDGE, SUB-CALIBER, 22MM, PRACTICE: Charge 1, M744	1305-00-334-5920	9287907	19203
CARTRIDGE, SUB-CALIBER, 22MM, PRACTICE: Charge 2, M745	1305-00-334-5922	9287908	19203
CARTRIDGE, SUB-CALIBER, 22MM, PRACTICE: Charge 3, M746	1305-00-334-5934	9287909	19203
CARTRIDGE, SUB-CALIBER, 22MM, PRACTICE: Charge 4, M747	1305-00-334-5935	9237910	19203
FLANGE NUT ASSEMBLY (TYPE IV)	1315-01-163-5428	9311189	19203

**Section III. FUNCTIONING****1-5. Sabot Loaded with Practice Round****WARNING**

- **HANDLE LOADED SABOTS WITH EXTREME CARE.**
- **ACCIDENTAL DROPPING OF A LOADED SABOT (TAIL DOWN) ON CERTAIN SURFACES (E.G., LOOSE GRAVEL) COULD CAUSE THE FIRING PIN OF THE FLANGE NUT ASSEMBLY TO STRIKE THE PERCUSSION PRIMER AND FIRE THE 22MM SUB-CALIBER CARTRIDGE.**
- **PERSONAL INJURY OR FATALITY COULD RESULT IF THE 22MM SUB-CALIBER PROJECTILE IS ACCIDENTALLY FIRED OUT OF THE SABOT.**

When the practice round (22mm sub-caliber cartridge) is loaded into the Sabot (fig. 1-3), the device is ready for firing. The protective plastic cap (fig. 1-2) covering the percussion cap of the sub-caliber cartridge must be removed prior to insertion into the Sabot. The loaded Sabot is dropped into the mortar tube (fig. 1-8A). The loaded Sabot impacts the firing pin of the weapon (fig. 1-8B). On impact, the firing pin or the flange nut assembly strikes and functions the percussion primer of the 22mm sub-caliber cartridge. The percussion cap ignites an ejection charge in the jet-housing assembly (fig. 1-9). The gases emerge through the eight axial holes in the jet screw assembly initiating travel of the Sabot and sub-caliber cartridge up the mortar tube (fig. 1-8B). Simultaneously, the ejection charge (fig. 1-9) ignites the sub-caliber projectile propelling charge, also contained in the jet housing assembly. This propels the sub-caliber projectile out of the cartridge case and through the barrel of the Sabot (fig. 1-8C). As the Sabot leaves the muzzle of the mortar (fig. 1-8D), the sub-caliber projectile clears the barrel of the Sabot (fig. 1-8C). The Sabot impacts the ground within four yards of the mortar tube, while the sub-caliber projectile continues its flight down range (fig. 1-10).

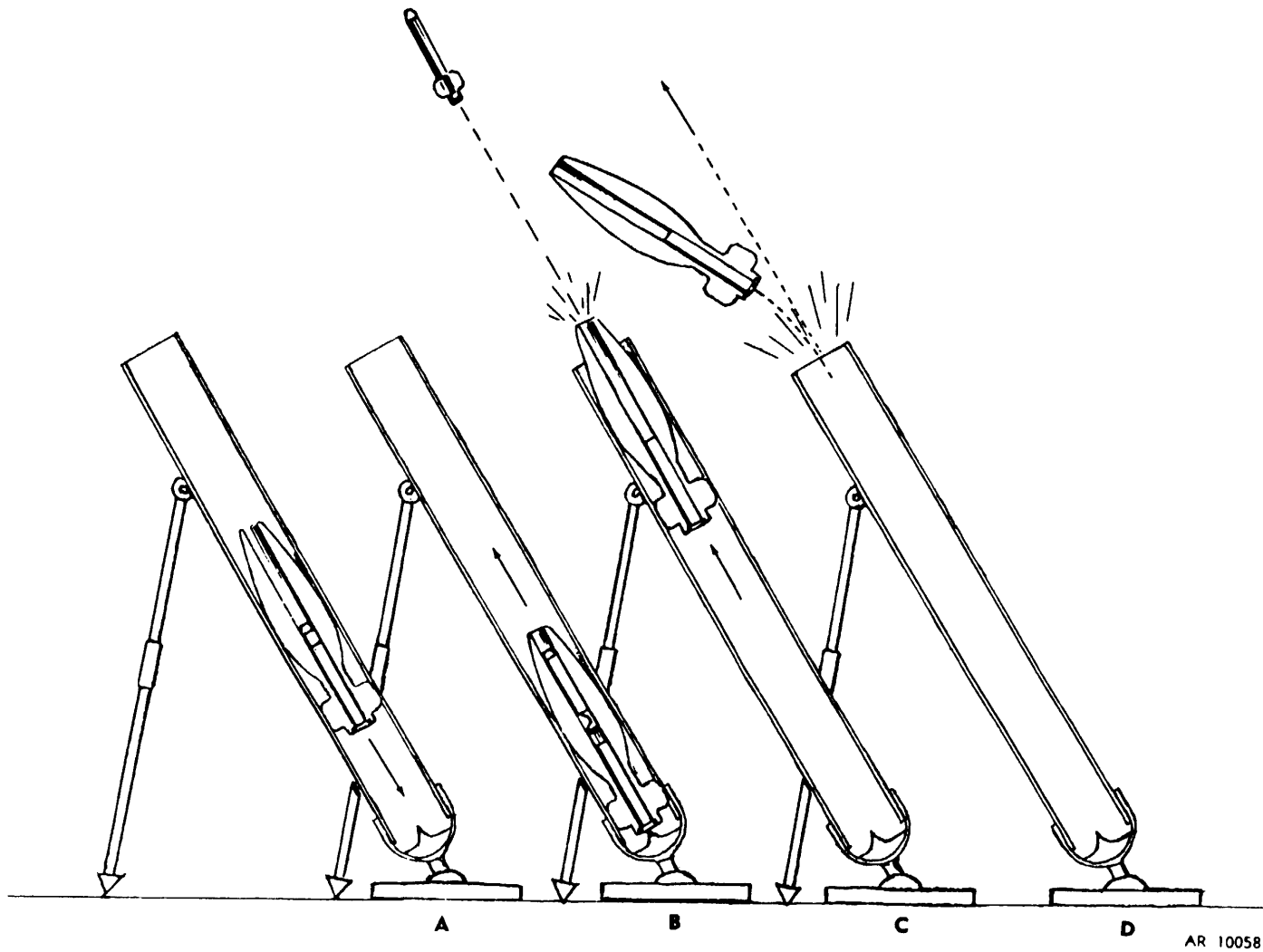

Figure 1-8. Firing of mortar training device and cartridge.

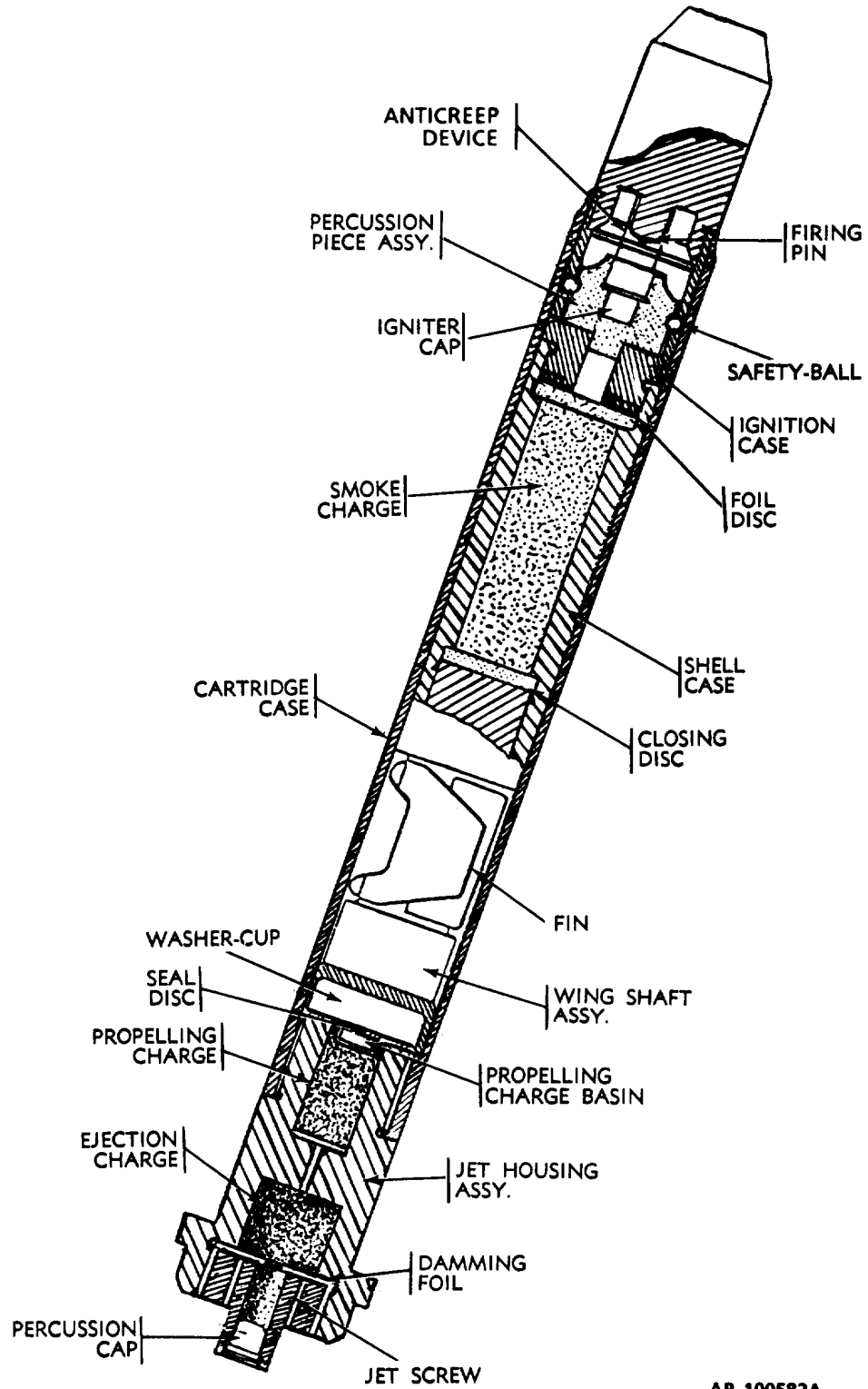

Figure 1-9. Cartridge cross section.



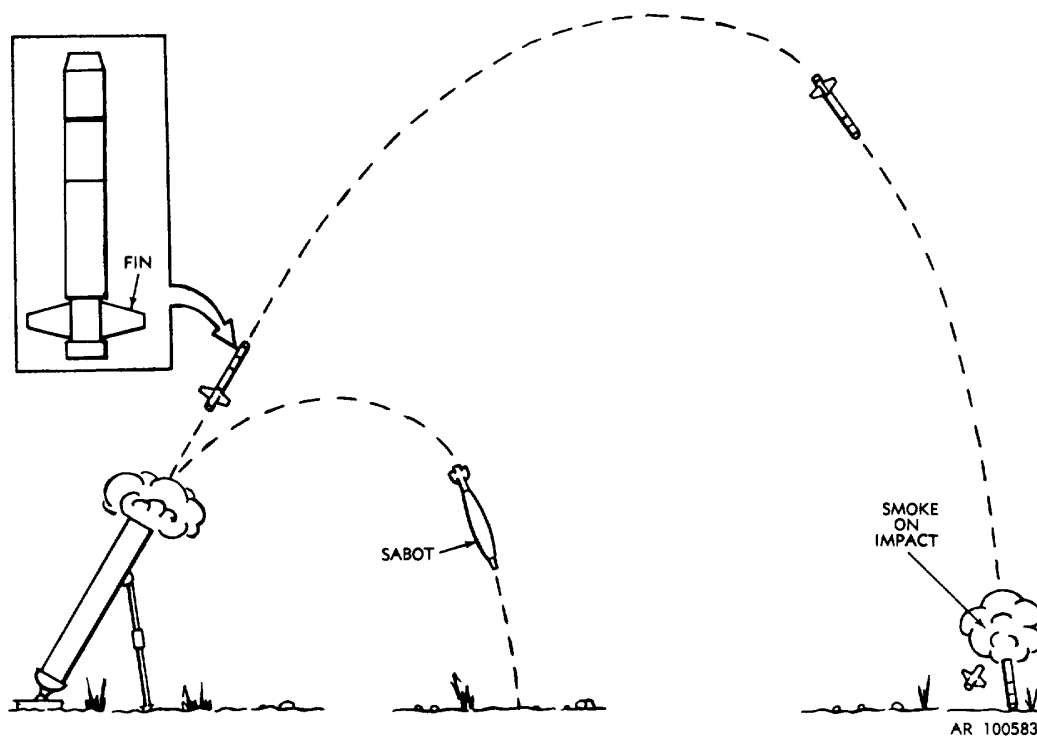

Figure 1-10. Diagram of Sabot and 22mm cartridge, firing to impact.

#### 1-6. 22MM Practice Cartridge

#### WARNING

**DO NOT FIRE TRAINING DEVICE (22MM SUB-CALIBER CARTRIDGES) THROUGH ANY OVERHEAD OBSTRUCTIONS.**

During firing the impact fuze is activated (fig. 1-9). This occurs only after the sub-caliber projectile has left the Sabot barrel. The percussion piece assembly which contains the primer for the fusing mechanism is held in position within the ignition case by two safety balls. When the projectile clears the Sabot barrel, the safety balls are free to move radially outward, freeing the percussion piece. The stabilizing fins (fig. 1-10) open as projectile clears the Sabot barrel, providing in-flight stability. On impact, the percussion piece moves forward allowing the igniter cap to strike the firing pin. The igniter cap initiates the smoke (spotting) charge (fig. 1-10), and gas pressure produced by the burning smoke charge ejects the wing piece assembly from the base of the shell case (fig. 1-11). The smoke charge produces a yellow cloud of smoke, visible from a distance of 500 meters. The initial confinement of the smoke by the wingshaft assembly produces an audible sound.

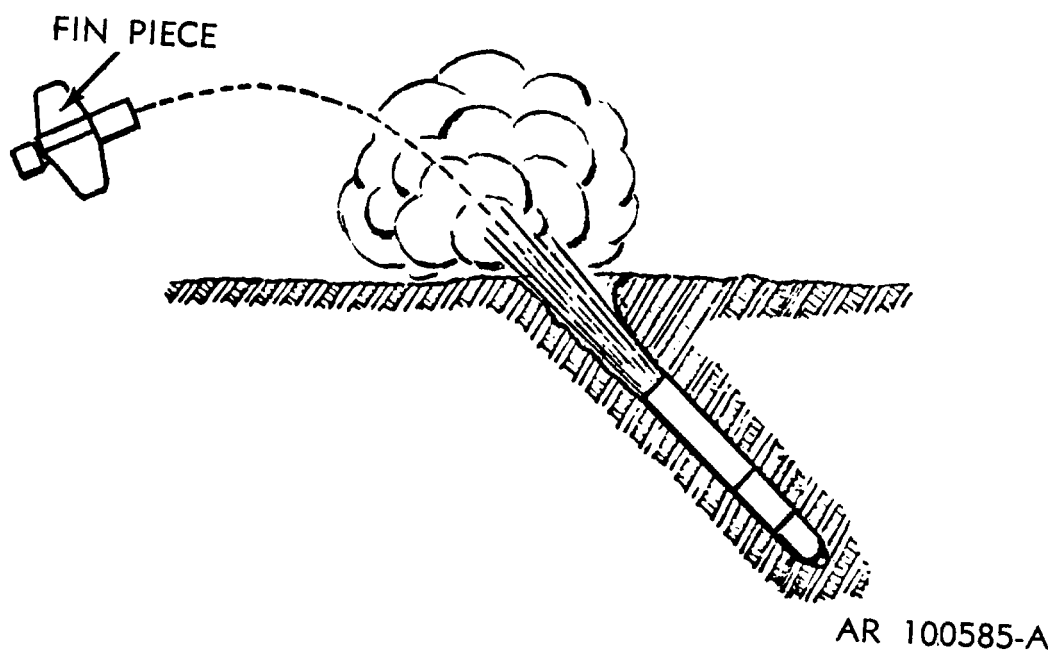

Figure 1-11. Optical and acoustical observation of target strikes.

## CHAPTER 2

OPERATING INSTRUCTIONS

---

## Section I. SAFETY PRECAUTIONS

## WARNING

WHEN HANDLING 81MM SABOT M1 ASSEMBLED WITH THE 22MM SUBCALIBER PRACTICE CARTRIDGE, M744, M745, M746, AND M747, EXERCISE CARE TO AVOID DROPPING THE SABOT. DROPPING THE SABOT END DOWN, EVEN WITH THE PROTECTIVE CAP IN PLACE, CAN CAUSE THE PRIMER TO FUNCTION RESULTING IN THE LAUNCH OF THE 22MM SUB-CALIBER PROJECTILE WHICH MAY RESULT IN INJURIES OR DEATH TO PERSONNEL.

**2-1. General**

- a. Except for the precautions contained in this manual, this ammunition is safe to handle and fire.
- b. The Sabot, 81mm, M1 is (INERT) and can be stored and handled as a dummy training round until it is loaded with the 22mm subcaliber practice cartridge at which time it will be handled as a live practice round of ammunition. When loaded and ready to fire, all safety precautions are to be observed for live ammunition.
  - b.1. Handle loaded Sabots with extreme care. Accidental dropping could cause the 22mm sub-caliber cartridge to fire. Personal injury or fatality could result.
- c. The 22mm sub-caliber practice cartridge contains propellant and smoke charge and will be stored and handled as live ammunition. Observe general safety precautions for fixed ammunition contained in TM 9-1300-206 and AR 385-63.
- d. Do not fire the practice ammunition over heads of troops.
- e. Do not fire the practice ammunition through overhead obstructions.

**2-2. Safety Area**

No personnel will enter the danger area (fig. 2-1) during firing of the practice ammunition.

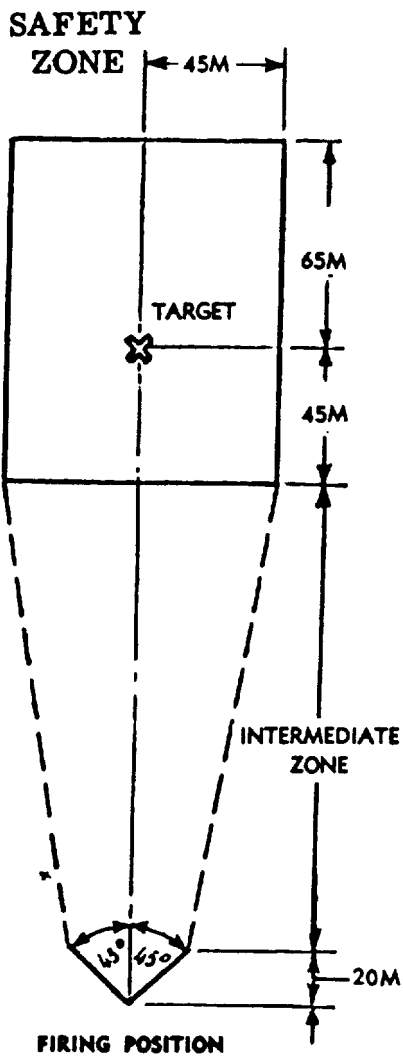

AR 100586

Figure 2-1. Recommended safety zone.

## 2-3. Firing Safety

a. Do not attempt to retrieve fired Sabots until firing of the mortar has stopped.

b. The following potentially hazardous conditions can arise during firing and should be handled as indicated below to avoid injury to personnel.

(1) *Misfire*. A misfire is the failure of a round to fire after it is dropped into the mortar when the firing mechanism selector is set on drop fire, or failure to fire after the trigger has been pulled when the selector is set for trigger fire. Misfires may be caused by defective ammunition, damaged firing pin, defective firing mechanism, propellant residue on the bore surface, or an obstruction in the bore that prevents the round from sliding all the way down the barrel. A misfire in itself is not dangerous, but since it cannot be immediately distinguished from a hangfire, it should be considered as a possible delayed firing until such possibility has been eliminated.

### **WARNING**

**NEVER ATTEMPT TO REMOVE A MISFIRED ROUND THAT IS CHAMBERED IN A HOT WEAPON DUE TO THE POSSIBILITY OF A COOK-OFF. ALL PERSONNEL SHOULD REMAIN CLEAR OF THE MUZZLE UNTIL THE WEAPON HAS COOLED.**

(2) *Hangfire*. A hangfire is a delay in the functioning of a propelling charge explosive train at the time of firing. The delay is unpredictable, and ranges from a fraction of a second to several minutes.

(3) *Cook-off*. A cook-off is the premature functioning of the propellant ignition system of a round chambered in a hot weapon without actuation by the firing pin. A cook-off would most likely be caused by the ignition of the propellant charge due to close proximity to the hot bore surface.

c. After failure to fire, follow misfire removal procedure (fig. 2-2) to remove round from weapon.

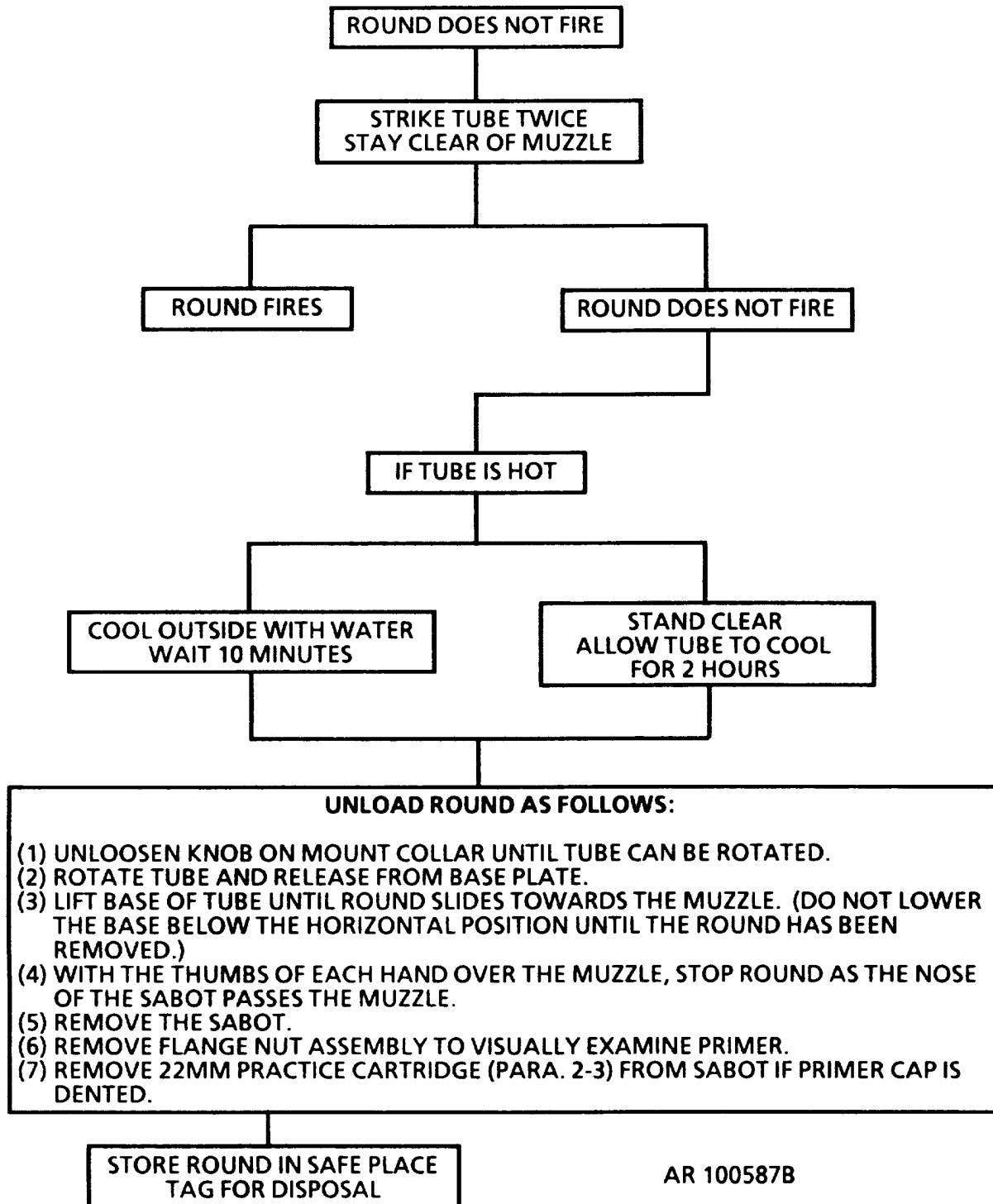

Figure 2-2. Misfire removal procedure.

c. 1. Unscrew flange nut assembly from Sabot.

d. If primer cap of 22mm cartridge is dented, remove from Sabot (fig. 2-7). Tag cartridge for destruction by authorized personnel.

e. If primer is not dented, cause of failure to fire may be due to a defective flange nut assembly or mortar firing mechanism. Notify unit maintenance for corrective action.

#### 2-4. Duds

Duds are cartridges which have been fired but have not functioned. All duds must be considered dangerous.

#### **WARNING**

**DO NOT TOUCH, MOVE OR OTHERWISE HANDLE DUDS. HAVE DUDS DESTROYED IN PLACE BY AUTHORIZED PERSONNEL ONLY.**

### Section II. OPERATING PROCEDURES

#### 2-5. Preparation for Firing

a. Assembly 22mm practice cartridge in Sabot.

#### **WARNING**

- **PERSONNEL MUST NOT STAND IN FRONT OR TO THE REAR OF THE SABOT WHEN INSERTING THE CARTRIDGE.**
- **HANDLE LOADED SABOTS WITH EXTREME CARE. ACCIDENTAL DROPPING COULD CAUSE THE 22MM SUBCALIBER CARTRIDGE TO FIRE. PERSONAL INJURY OR FATALITY COULD RESULT.**
- **USE TYPE IV FLANGE NUT ASSEMBLIES (SEE FIGURE 1-4) ONLY.**

- (1) Remove Sabot from packing box (see para. 2-5b for fired Sabot).
- (2) Inspect bore and chamber. Clean if necessary (para. 3-2).
- (3) Remove flange nut from Sabot by unscrewing counterclockwise (fig. 2-3).
- (4) Remove 22mm cartridge from ammunition box.
- (5) Insert 22mm practice cartridge into chamber of Sabot (fig. 2-4).
- (6) Remove plastic protector cap from percussion cap (fig. 2-5).
- (7) Screw flange nut on to Sabot, hand tighten (fig. 2-6).

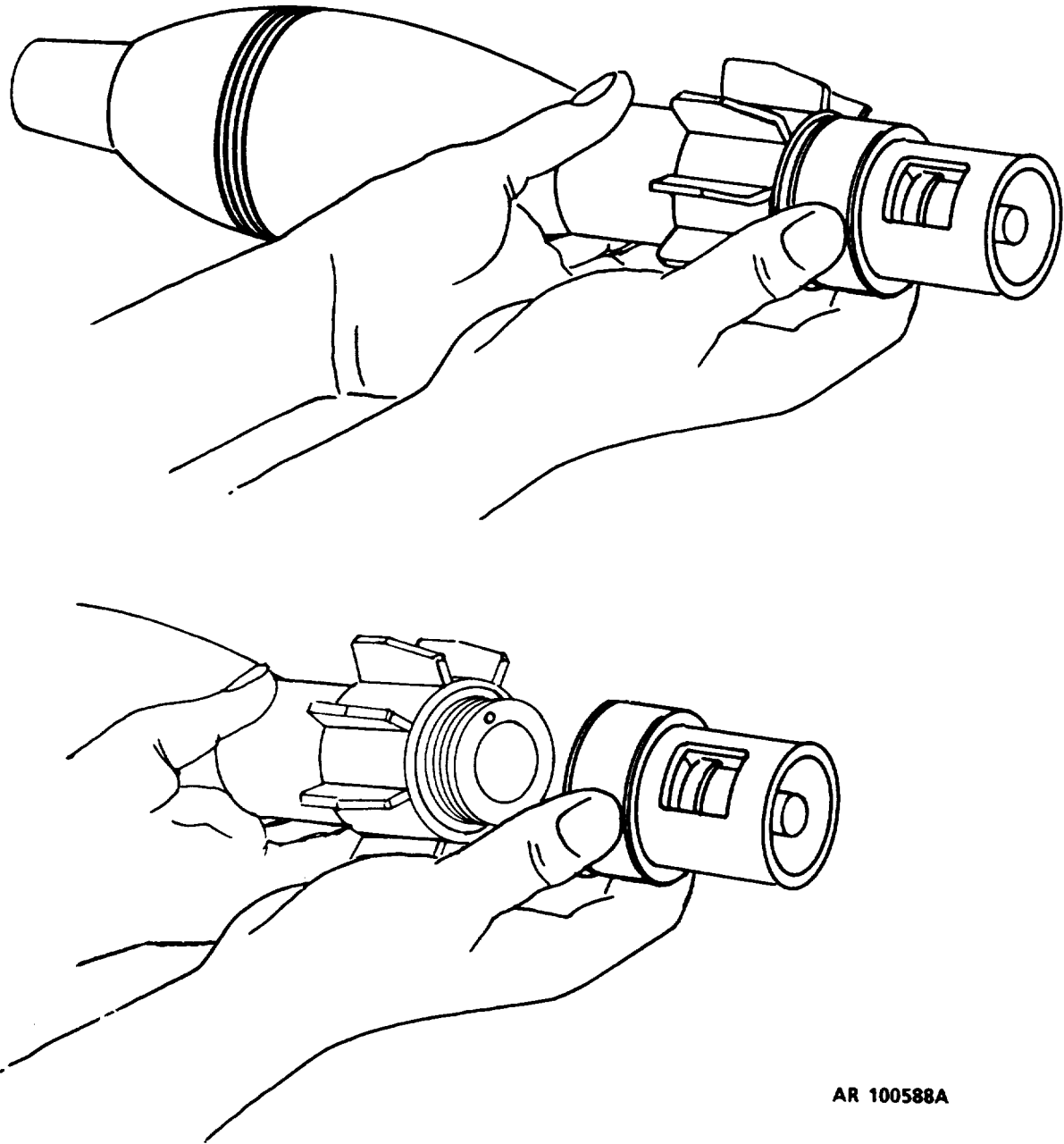

AR 100588A

Figure 2-3. Removal of flange nut.



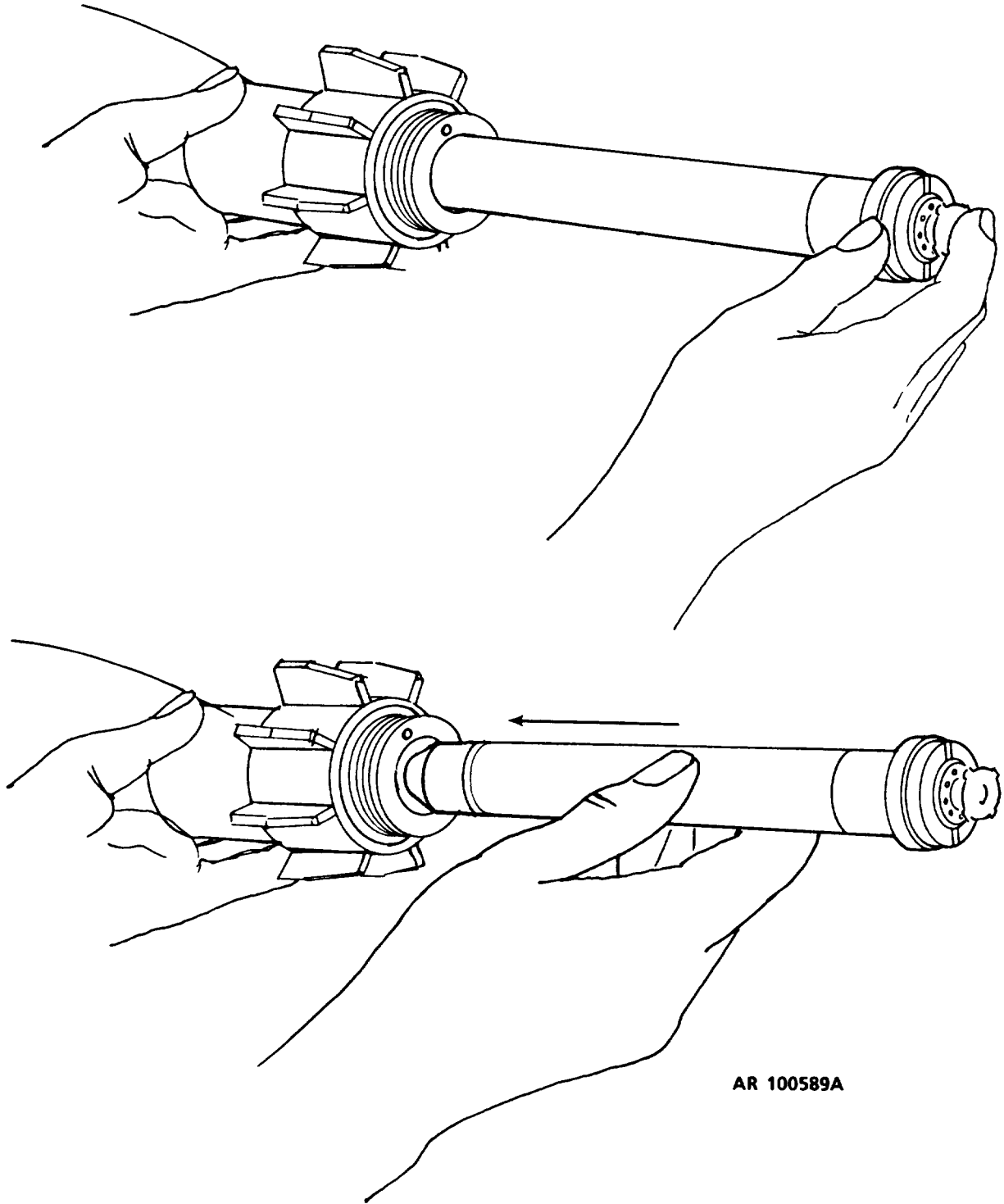

AR 100589A

Figure 2-4. Insertion of cartridge.

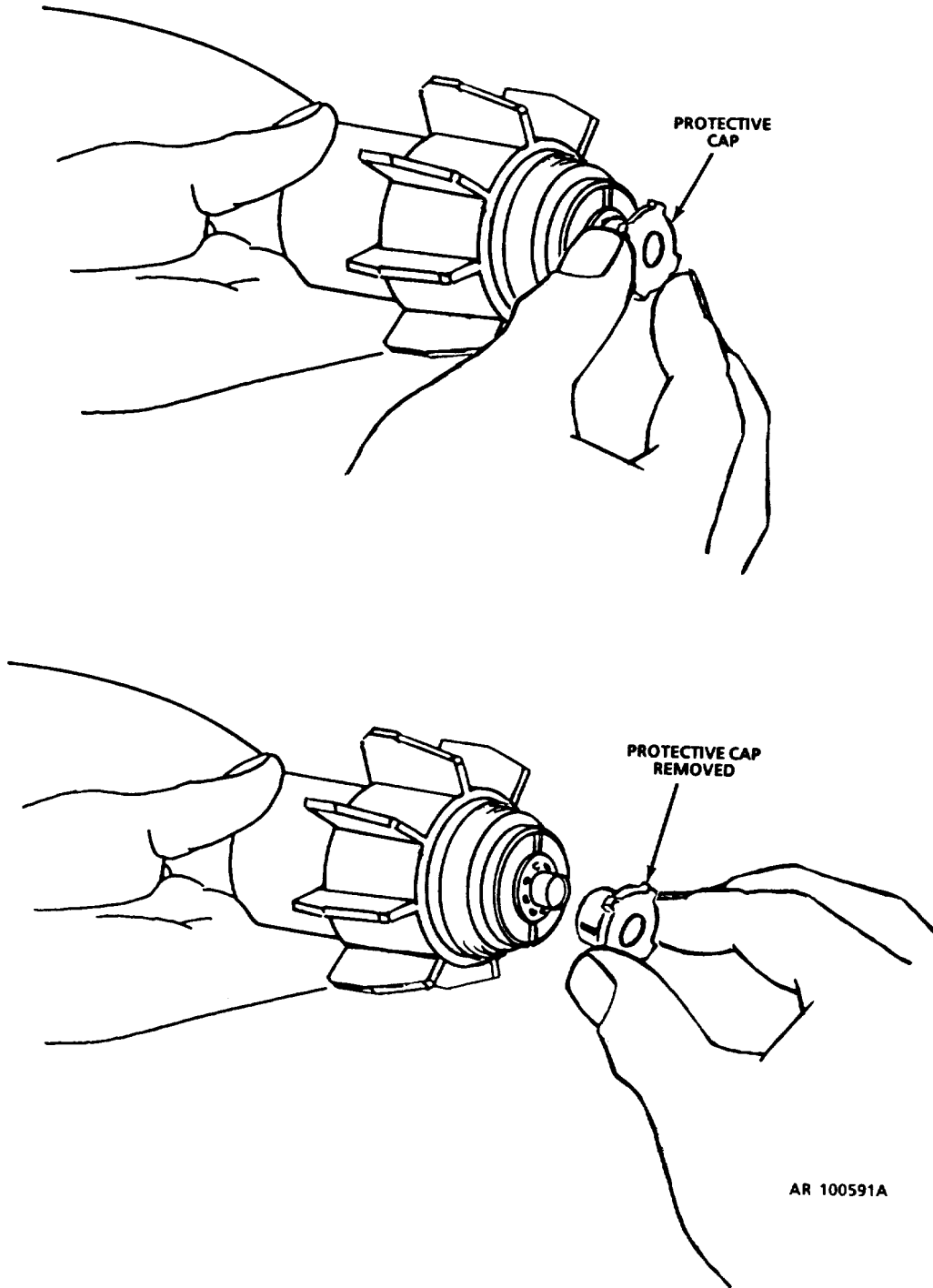

AR 100591A

Figure 2-5. Removal of safety cap.

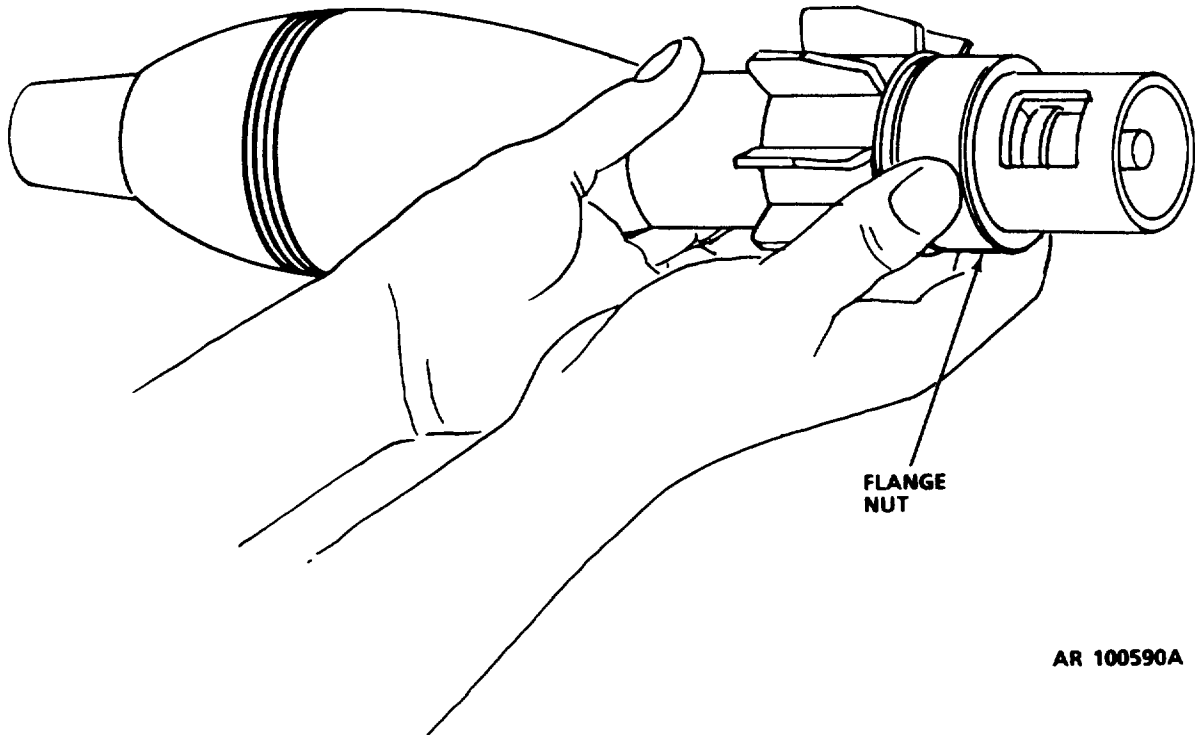

AR 100590A

Figure 2-6. Replacement of flange nut.

b. For retrieved Sabots after firing: Remove flange nut, pull out fired cartridge case (fig. 2-7). Clean chamber (para. 3-2).

c. Prior to firing, the ground in front of the mortar should be covered with canvas or plastic or vinyl material to protect the Sabot from dirt or mud after the ejection from the mortar barrel.

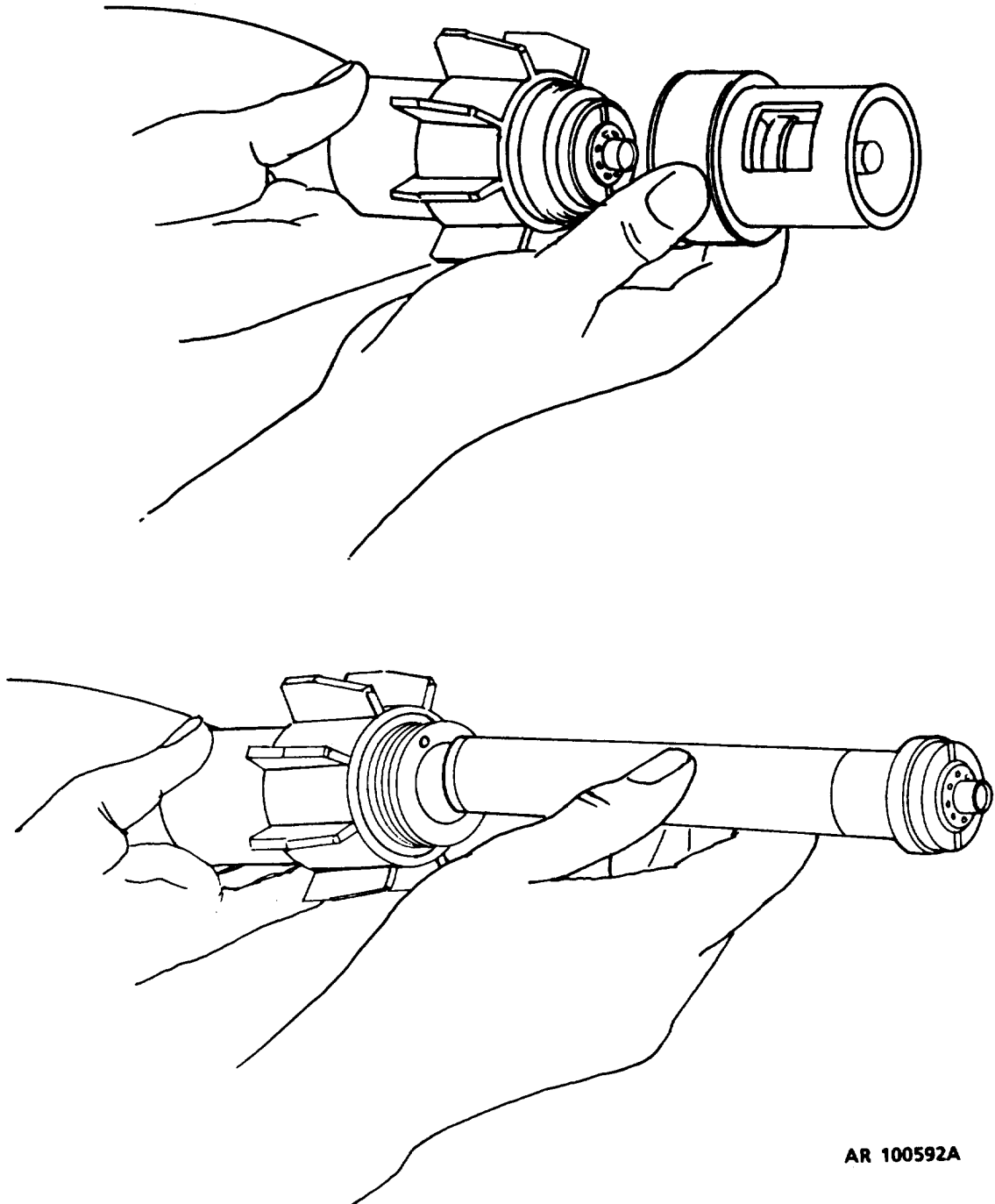

AR 100592A

Figure 2-7. Removal of fired cartridge.

**2-6. Firing**

- a. Prepare the mortar for firing. See appropriate technical manual for specific model mortar being used.
- b. Prepare the ammunition for firing (para. 2-5).
- c. Use firing table (fig. 2-8).
- d. Insert the practice ammunition in the same manner as specified for service ammunition.

\* PROVISIONAL  
 FIRING TABLE FOR 81MM  
 SABOT, M1, USING 22MM  
 PRACTICE CARTRIDGE, M744  
 (CHARGE 1), M745 (CHARGE 2),  
 M746 (CHARGE 3), AND M747  
 (CHARGE 4)

Charge 1		
Range	Elevation	Time of flight
m	mils	sec
70	1416	8.9
75	1402	8.8
80	1388	8.8
85	1373	8.6
90	1359	8.8
95	1345	8.7
100	1320	8.7
105	1314	8.7
110	1299	8.6
115	1283	8.6
120	1266	8.5
125	1249	8.5
130	1232	8.4
135	1214	8.4
140	1195	8.3
145	1175	8.2
150	1155	8.2
155	1133	8.1
160	1109	8.0
165	1084	7.9
170	1057	7.7
175	1029	7.9
180	997	7.9
185	958	7.3
190	910	7.9
195	800	6.4
200		
205		
210		
215		
220		
225		
230		
235		
240		
245		
250		
255		
260		
265		
270		
275		
280		
285		
290		
295		
300		
305		
310		
315		
320		
325		
330		

CHARGE 2	
Elevation	Time of flight
mils	sec.
1283	9.5
1269	9.5
1255	9.4
1241	9.4
1226	9.3
1211	9.3
1196	9.2
1179	9.1
1162	9.1
1144	9.0
1126	8.9
1107	8.9
1087	8.7
1066	8.6
1044	8.5
1019	8.4
992	8.3
962	8.1
923	7.9
870	7.5

CHARGE 3	
Elevation	Time of flight
mils	sec.
1253	11.2
1242	11.1
1232	11.1
1221	11.0
1209	11.0
1198	10.9
1187	10.9
1175	10.8
1164	10.8
1152	10.7
1139	10.7
1127	10.0
1114	10.5
1100	10.5
1085	10.4
1071	10.3
1055	10.2
1039	10.1
1021	10.0
1002	9.9
982	9.8
959	9.6
933	9.4
900	9.2
854	8.8

Charge 4		
Range	Elevation	Time of flight
m	mils	sec
335	1153	12.4
340	1144	12.3
345	1134	12.3
350	1124	12.2
355	1114	12.8
360	1104	12.1
365	1093	12.0
370	1082	12.0
375	1071	11.9
380	1059	11.8
385	1049	11.7
390	1034	11.6
395	1021	11.5
400	1007	11.4
405	992	11.3
410	976	11.2
415	958	11.1
420	939	10.9
425	916	10.3
430	891	10.5
435	852	10.2

CHARGE 1  $V_0 = 45$  m/sec.  
 CHARGE 2  $V_0 = 50$  m/sec.  
 CHARGE 3  $V_0 = 60$  m/sec.  
 CHARGE 4  $V_0 = 70$  m/sec.

Weight of the projectile: 300g  
 Density of the air: 1225g/m<sup>3</sup>  
 Temperature: 15° C (60° F)

\*Subject to verification testing.

AR 100593

Figure 2-8. Firing table for 81mm Sabot, M1, using 22mm practice cartridge.

## **2-7. During Firing**

Immediately after firing every tenth (10) Sabot, clean the bore of the mortar tube as specified for operator/crew maintenance in TM 9-1015-20012. Assure that the mortar tube (bore) is clean and dry prior to resumption of fire.

## **2-8 Cancellation of Firing**

If ammunition (Sabot with 22mm practice cartridge) was prepared for firing but not fired, disassemble as follows: **WARNING PERSONNEL MUST NOT STAND IN FRONT OR TO THE REAR OF THE SABOT WHEN REMOVING THE CARTRIDGE.**

- a. Remove flange nut from Sabot.
- b. Replace plastic protector cap.
- c. Remove cartridge from Sabot.
- d. Return 22mm practice cartridge to packing box.

## **2-9. Operation Under Extreme Weather Conditions**

Ammunition should be kept clean and dry. Cover ammunition with canvas to protect from moisture, hot rays of sun, sand, or snow and ice, as applicable.



**CHAPTER 3**  
**OPERATOR MAINTENANCE**

---

**3-1. Prior to Firing**

a. Requisition required materials as indicated in appendix B.

b. *Mortar.* Perform preventive maintenance as required by technical manual for the mortar model being used. Assure that the mortar tube is clean and dry.

c. *Sabot.* Assemble cleaning staff (fig. 3-1) by rotating end staff clockwise into thread end of staff handle. Clean the bore of the Sabot using the cleaning wick (fig. 3-1) attached in slot of end staff and saturated with rifle bore cleaner (see app. E). Thoroughly dry bore with clean dry wick attached to staff. Depress the firing pin of the flange nut assembly (fig. 1-4) prior to loading to assure that it is free to strike the primer of 22mm sub-caliber cartridge. Lubricate the firing pin (as required).

**3-2. During Firing**

See para. 2-7.

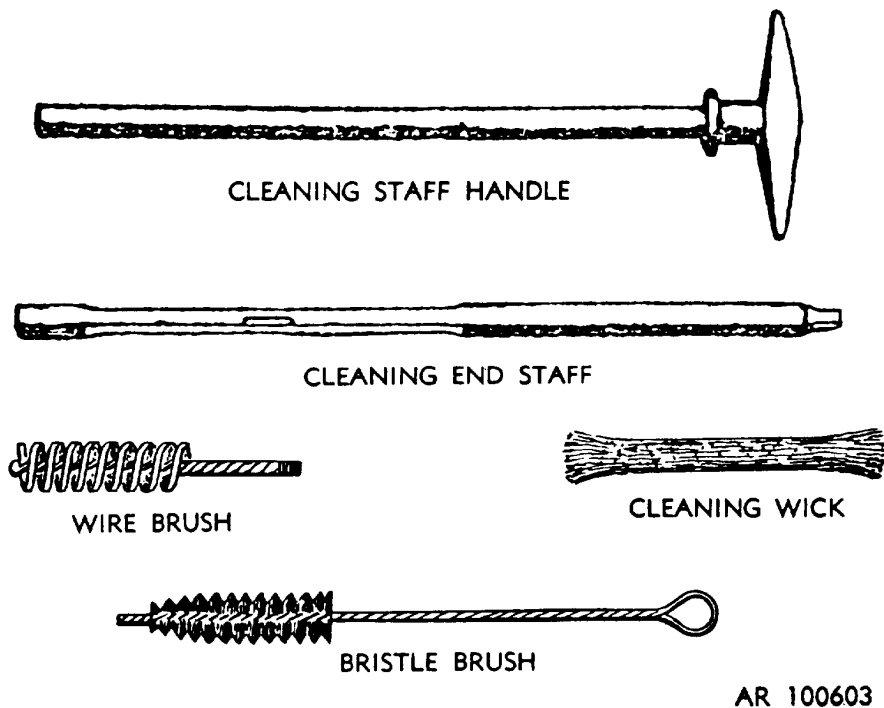

Figure 3-1. Cleaning staff assembly, cleaning wick and brushes.

**3-3. After Firing**

- a. After recovery of the Sabot, the fired cartridge is removed from the chamber of the Sabot by removing the flange nut from the Sabot and pulling out the fired cartridge case (fig. 2-7).
- b. Use bristle brush (fig. 3-1) to clean dirt off outer surfaces and threads of Sabot.
  - b.1. Use bristle brush (fig. 3-1) to clean dirt and powder residue from the outer surface and threads of the flange nut assembly.
- c. Attach wick to slot in end staff. Saturate wick in rifle bore cleaner. Run saturated wick through bore of Sabot repeatedly until clean.
- d. Remove wick from end staff and attach wire brush (fig. 3-1) to staff. Insert in Sabot and remove powder fouling by running through full length of Sabot bore.
- e. Repeat b and c above until bore is clean.
- f. If Sabot is to be refired, place clean wick on staff end and run through bore of Sabot to dry.
- g. If Sabot is to be replaced in carrying case, a thin film of bore cleaner should remain in the bore and on the firing pin of the flange nut assembly. Repeat this cleaning operation after 3 days, leaving a light film of rifle bore cleaner on the bore of the Sabot.

## CHAPTER 4

UNIT MAINTENANCE

---

**4-1. General**

a. Maintenance at the unit level is performed by designated personnel in using units. Its purpose is to prevent further deterioration of ammunition which may have been exposed to rough handling or adverse weather conditions. Direct support units may be called upon to provide technical assistance and packaging materials.

b. Responsibilities for maintenance are limited to those functions specified in appendix B, Maintenance Allocation Chart (MAC). Only maintenance operations for which procedures are given in this manual, TM 9-1300-251-20, or in the weapon operator's manual are authorized.

c. Maintenance shall be performed at least 90 feet from any ammunition storage shelter or magazine area.

d. Refer to TM 9-1300-251-20 for inspection, marking and repair of packaging materials; and cleaning and touch-up painting of ammunition.

**4-2. Sabot**

a. Assure that operator maintenance (specified in para. 3-2) has been performed prior to returning Sabot carrying case to unit storage area.

**WARNING**

**INSPECT EACH SABOT TO ASSURE THAT IT DOES NOT CONTAIN 22MM PRACTICE CARTRIDGES.**

b. Inspect Sabot for powder fouling and pits or rust in bore. Repeat cleaning (para. 3-2) if required.

c. Inspect Sabot for missing flange nut, broken wings or damaged threads or body. Notify direct support maintenance for disposition.

d. Inspect the flange nut assembly. Depress the firing pin (fig. 1-4) to assure that it is free. Lubricate the firing pin (as required) with rifle bore cleaner.

**4-3. 22mm Sub-Caliber Practice Cartridge**

a. Unless packing box shows evidence of moisture or damage to the extent that contents may be unusable, do not open until material is to be used.

b. When all cartridges in a box are not used, mark boxes as described in TM 9-1300-251-20, paragraph 3-17 (light box).

c. For disposition of damaged items contact direct support personnel. Contact EOD personnel for disposition of ammunition items considered to be hazardous.

APPENDIX A

REFERENCES

**A-1. ADMINISTRATIVE PUBLICATIONS**

a. Publication Index. The following publication index should be consulted frequently for latest changes or revisions of references given in this appendix and for new publications relating to the material covered in this manual.

Consolidated Index of Army Publications and Blank Forms..... DA PAM 25-30

b. Army Regulations.

Reporting of Transportation Discrepancies in Shipments ..... AR 55-38  
 Environmental Protection and Enhancement..... AR 200-1  
 Army Safety Program..... AR 385-10  
 Accident Reporting and Records ..... AR 385-40  
 Fire Prevention and Protection..... AR 420-90  
 Ammunition Peculiar Equipment (APE)..... AR 700-20 and DARCOM Supp 1  
 Worldwide Ammunition Reporting System (WARS) ..... AR 700-22  
 Reporting of Item and Packaging Discrepancies..... AR 735-11-2

c. AMC/DARCOM Regulations.

Industrial, Medical & Hygiene Considerations..... AMCR 40-2  
 Preparation of Standing Operating Procedures (SOP's) for Ammunition Operations..... AMC-R 700-107  
 Hazard Analysis for Facilities, Equipment, and Process Development..... DARCOM-R 385-3  
 Safety Manual ..... AMC-R 385-100  
 Depot Maintenance Program Scheduling, Workloading, and Reporting System ..... DARCOM-R 750-28  
 Authorizing and Reporting of Demilitarization of Class V Materiel ..... AMC-R 755-8

d. Military Standards.

Sampling Procedures and Tables for Inspection by Attributes ..... M1L-STD-105  
 Sampling Procedures and Tables for Inspection by Variables for Percent Defective ..... - M1L-STD-414  
 Ammunition Data Cards ..... M1L-STD-1167  
 Lot Numbering of Ammunition..... M1L-STD-1168

**A-2. BLANK FORMS**

Propellant Acceptance Sheet .....ARRCOM Form 210 R  
 Discrepancy in Shipment Report .....SF 361  
 Report of Discrepancy (ROD) .....SF 364  
 U.S. Army Accident Investigation Report .....DA Form 285  
 Recommended Changes to Publications and Blank Forms.....DA Form 2028  
 Ammunition Condition Report .....DA Form 2415  
 Fire Report .....DA Form 3985  
 Ammunition Transfer Record .....DA Form 4508

**A-3. EQUIPMENT PUBLICATIONS**

a. Technical Manuals.

Army Ammunition Data Sheets - Artillery Ammunition  
 for Guns, Howitzers, Mortars, Recoilless Rifles,  
 Grenade Launchers, and Artillery Fuses .....TM 43-0001-28  
 Organizational Maintenance Manual, Artillery Ammo .....TM 9-1300-251-20  
 Direct Support and General Support Maintenance  
 Manual for Artillery Ammunition .....TM 9-1300-251-34  
 Army Equipment Data Sheets - Ammunition  
 Peculiar Equipment .....TM 43-0001-47  
 Ammunition, General .....TM 9-1300-200  
 Ammunition and Explosive Standards .....TM 9-1300-206  
 Military Explosives .....TM 9-1300-214  
 Ammunition Maintenance .....TM 9-1300-250  
 General Instructions for Demilitarization/Disposal of  
 Conventional Munitions .....TM 9-1300-277  
 Operator's and Organizational Maintenance Manual -  
 Demolition Materials .....TM 9-1375-213-12

b. Technical Bulletins.

Ammunition: National Stock Numbers and  
 Department of Defense Ammunition Codes .....TB 9-1300-256  
 Munitions: Suspended or Restricted .....TB 9-1300-385  
 Occupational and Environmental Health:  
 Hearing Conservation .....TB MED 501  
 Occupational and Environmental Health Respiratory  
 Protection Program .....TB MED 502

c. Air Force Technical Orders.

Storage and Maintenance Procedures  
 CBU-7A/A, CBU-38/A, CBU-38A/A,  
 CBU-38B/A, AND CBU-38C/A  
 Aircraft Bomb Dispensers .....TO 11A9-20-7

**A-4. SUPPLY BULLETINS**

Ammunition Surveillance Procedures .....SB 742-1  
 Charge, Propelling, Various and Propellant, Bulk,  
 Ammunition Surveillance Procedures .....SB 742-1300-94-2  
 Disposition of Used Ammunition Packing Material  
 and Certain Specified Ammunition Components .....SB 755-

**A-5. SPECIAL REQUIREMENTS**

Code of Federal Regulations ..... Title 49  
Complete Round Charts Artillery Ammunition ..... DARCOM-P 700-3-3  
Defense Demilitarization Manual ..... DOD 4160.21-M-1  
DOD Consolidated Ammunition Catalog  
Joint Hazard Classification System  
Resource Conservation and Recovery Act (PL 89-272, as amended by PL 91-512,  
PL 93-611, and PL 94-580).  
The Army Maintenance Management System (TAMMS) ..... DA Pam 738-750  
ARMS Packaging File  
Explosives and Demolition's ..... FM 5-25

**A-3/(A-4 blank)**

APPENDIX B

MAINTENANCE ALLOCATION CHART

Section I. INTRODUCTION

**B-1. General**

- a. The Maintenance Allocation Chart designates responsibility for the performance of maintenance functions.
- b. Only the lowest level of maintenance authorized to perform a maintenance function is indicated.
- c. A maintenance function assigned a maintenance level will automatically be authorized to be performed at any higher maintenance level.
- d. A maintenance function that cannot be performed at the assigned level of maintenance for any reason may be evacuated to the next higher maintenance organization. Higher maintenance levels will perform the maintenance functions of lower maintenance levels when required or directed by the appropriate commander.

**B-2. Maintenance Functions**

The implementation of maintenance tasks will be consistent with the assigned maintenance in accordance with the following definitions:

- a. *Inspect.* To determine the serviceability of an item by comparing its physical, mechanical, and/or electrical characteristics with established standards through examination.
- b. *Test.* To verify serviceability and to detect incipient failure by measuring the mechanical or electrical characteristics of an item and comparing those characteristics with prescribed standards.
- c. *Service.* Operations required periodically to keep an item in proper operating condition.
  - (1) *Unpack.* To remove item from packing box for service or for the performance of other maintenance operations.
  - (2) *Repack.* To return item to packing box after service or other maintenance operations.
  - (3) *Clean.* To rid the item of contamination.
  - (4) *Touch up.* To spot paint scratched or blistered surfaces.
  - (5) *Mark.* To restore obliterated identification.
- d. *Install.* To emplace, seat or fix into position an item in a manner to allow the proper functioning of the equipment; also to assemble one component of an end item with another.
- e. *Adjust.* To maintain within prescribed limits by bringing into proper or exact position, or by setting the operating characteristics to the specified parameters.
- f. *Renovate.* To restore item to serviceable condition.
  - (1) *Paint.* To repaint the entire item.
  - (2) *Repair.* To restore serviceability to an item by correcting specific damage, fault, malfunction, or failure through the application of maintenance services or other maintenance actions.
  - (3) *Replace.* To substitute a serviceable component in a manner to allow the proper functioning of equipment.

**B-3. Explanation of Format**

- a. *Group Number.* Column 1 lists the group numbers which identify components and assemblies with the next higher assembly.
- b. *Functional Group.* Column 2 lists the item names of parts and assemblies on which maintenance is authorized.
- c. *Maintenance Function.* Column 3 lists the twelve maintenance functions defined in B-2 above. Capital letters are inserted under appropriate maintenance functions, on line with each functional group, to indicate the lowest level of maintenance authorized to perform that function. Symbols used and the maintenance category each represents are as follows:

Symbol	Explanation
C .....	Operator/Crew
O .....	Organizational
F .....	Direct Support
D .....	Depot

**Section II. MAINTENANCE ALLOCATION CHART**

(1) GROUP NUMBER	(2) Functional group	(3) Maintenance functions											(4) Tools and equipment	(5) Remarks	
		SERVICE							RENOVATE						
		I N S P E C T	T E S T	U N P A C K	R E P A C K	C L E A N	T O U C H U P	M A R K	I N S T A L L	A D J U S T	P A I N T	R E P A I R			R E P L A C E
0101	01 GROUP, FIXED AMMUNITION a. CARTRIDGE, Practice, Sub-caliber, 22mm, M744, M745, M746, M747	C	D	C	C	C	O	F	C	-	F	D	-		
0102	b. Packing for cartridge a. Sabot, 81mm, M1(INERT) b. Packing for Sabot c. Flange nut assembly	O C O C	- - - -	C C C -	C C C -	C C C C	O - O -	O - O -	- C - C	- - - O	O - O -	O F O -	O - O C		



**APPENDIX C**

**BASIC ISSUE ITEMS LIST**

---

(not applicable)

**C-1/(C-2 blank)**

## APPENDIX D

## REPAIR PARTS AND SPECIAL TOOLS LIST

## Section I. INTRODUCTION

**D-1. Scope**

This appendix lists repair parts; special tools; and other support equipment required for operation and performance of organizational, direct support, and general support maintenance of the 81mm Sabot (INERT) and 22mm sub-caliber practice cartridge.

**D-2. General**

This appendix is divided into the following sections:

- a. *Section II. Repair Parts List.* A list of repair parts authorized for use in the performance of maintenance.
- b. *Section III. Special Tools List.* A list of special tools, and support equipment authorized for the performance of maintenance at the organizational level.
- c. *Section IV. Cleaning Tools List.* A list of expendable cleaning items authorized for use in the performance of maintenance.

**D-3. Explanation of Columns**

The following provides an explanation of columns found in the tabular listings:

- a. *Illustration.* This column is divided as follows:

- (1) *Figure number.* Indicates the figure number of the illustration in which the item is shown.
- (2) *Item number.* The number, if any, used to identify each item called out in the illustration.

- b. *Source, Maintenance, and Recoverability Codes (SMR).*

(1) *Source code.* Source codes are assigned to support items to indicate the manner of acquiring support items for maintenance, repair or overhaul of end items. Source codes are entered in the first and second positions of the Uniform SMR Code format as follows:

Code	Definition
PE	Support equipment procured and stocked for initial issue or outfitting to specified maintenance repair activities.
XB	Item is not procured or stocked. If not available through salvage, requisition.

(2) *Maintenance code.* Maintenance codes are assigned to indicate the levels of maintenance authorized to USE and REPAIR support items. The maintenance codes are entered in the third and fourth positions of the Uniform SMR Code format as follows:

(a) The maintenance code entered in the third position will indicate the lowest maintenance level authorized to remove, replace, and use the support item. The maintenance code entered in the third position will indicate one of the following levels of maintenance.

Code	Application/Explanation
C	Crew or operator maintenance performed within organizational maintenance.
O	Support item is removed, replaced, used at the organizational level.

(b) The maintenance code entered in the fourth position indicates whether the item is to be repaired and identifies the lowest maintenance level with the capability to perform complete repair (i.e., all authorized maintenance functions). This position will contain one of the following maintenance codes:

Code	Application/Explanation
O	The lowest maintenance level capable of complete repair of the support item is the organizational level.
Z	Nonreparable. No repair is authorized.

(3) *Recoverability code.* Recoverability codes are assigned to support items to indicate the disposition action on unserviceable items. The recoverability code is entered in the fifth position of the Uniform SMR Code format as follows:

Codes	Definition
Z	Nonreparable item. When unserviceable, condemn and dispose at the level indicated in position 3.
O	Reparable item. When uneconomically repairable, condemn and dispose at organizational level.

c. *National Stock Number.* This column indicates the National stock number assigned to the item and will be used for requisitioning purposes.

d. *Part Number.* This column indicates the primary number used by manufacturer (individual, company, firm, corporation, or government activity) which controls the design characteristics

of the item by means of its engineering drawings, specifications standards, and inspection requirements, to identify an item or range of items.

e. *Federal Supply Code for Manufacturers (FSCM)*. This column indicates a 5-digit numeric code used to identify the manufacturer, distributor, or Government agency that controls the design characteristics of the item.

f. *Description*. This column indicates the Federal item name and any additional description of the item required.

g. *Unit of Measure (U/M)*. A two character alphabetic abbreviation indicating the unit upon which the allowances are based; e.g., ft, ea, pr, etc.

h. *Quantity Incorporated in Unit*. This column indicates the quantity of the item used with or on the equipment.

**D-1. Abbreviations**

brz	bronze
hdl	handle
diam	diameter
o a	overall
rd	round
thd	thread

**Section II. REPAIR PARTS LIST**

(1) ILLUSTRATION		(2)	(3)	(4)	(5)	(6)	(7)	(8)
FIG NO.	ITEM NO.	SMR CODE	NATIONAL STOCK NUMBER	PART NO. CODE FOR MFG	FED SUPPLY	DESCRIPTION	U/M	QTY INC IN UNIT
1-4	-	XBOOO	1315-01-163-5428	9311189	19203	FLANGE NUT ASSEMBLY (TYPE IV)	ea	1
1-5	-	XBOOO	-	E. WaltersCo. 882109	-	BOX, PACKING, WOOD: (for 81mm) Sabot (inert)	ea	1

Section III. SPECIAL TOOLS LIST

(1) ILLUSTRATION		(2)	(3)	(4)	(5)	(6) DESCRIPTION	(7)	(8) QTY INC IN U/M UNIT
FIG	ITEM NO.	SMR CODE	NATIONAL STOCK NUMBER	PART NUMBER	FED SUPPLY CODE FOR MFG			
3-1	-	PECZZ	1005-00-610-8828	6108828	19206	BRUSH, CLEANING, SMALL ARMS: spiral tapered rd, chunking bristle, 1 brush Dina, 3 brush lg, 11 1/8 o/a lg, w/hdl	ea	1
3-1	-	PECZZ	1005-00-722-5087	7225087	19205	BRUSH, CLEANING, SMALL ARMS: spiral rd, thd end, ph brz wire, 5/16-18NC-2A, 0.980 brush dia. 3 5/8 brush lg, 5 1/4 o/a lg.	ea	1
3-1	-	PECZZ	1010-00-832-9153	11687054	19204	STAFF, CLEANING: staff and handle assembly	ea	1
3-1	-	PECZZ	1015-00-790-3611	8766008	19206	SECTION END: CLEANING STAFF: 20mm	ea	1

D-3/(D-4 blank)

## APPENDIX E

## CONSUMABLE MAINTENANCE SUPPLIES AND MATERIALS

---

National stock No.	Part No.	Federal supply Code manufacturing	Description	Unit of issue
1005-00-072-0758	11578001	19204	WICK, CLEANING (bag of 100)	bag
6850-00-224-6663	M1L-C-372	81349	CLEANING COMPOUND, RIFLE BORE: solution type (1 gal can)	gal

E-1/(E-2 blank)

By Order of the Secretary of the Army:

CARL E. VUONO  
*General, United States Army,*  
*Chief of Staff*

Official:  
THOMAS F. SIKORA  
*Brigadier General, United States Army,*  
*The Adjutant General*

Distribution:

To be distributed in accordance with DA Form 12-40-E, Operator's and Unit Maintenance Requirements for Training Device, Mortar, 81MM, Sabot, Inert; Sub-Caliber Practice Cartridge M744/745/746/747 (TM 9-1315-249-series).

\*U.S. GOVERNMENT PRINTING OFFICE: 1990-743-0049:20256

RECOMMENDED CHANGES TO EQUIPMENT TECHNICAL PUBLICATIONS



THEN...JOT DOWN THE  
DOPE ABOUT IT ON THIS FORM.  
CAREFULLY TEAR IT OUT, FOLD IT  
AND DROP IT IN THE MAIL.

**SOMETHING WRONG WITH PUBLICATION**

FROM: (PRINT YOUR UNIT'S COMPLETE ADDRESS)

DATE SENT

PUBLICATION NUMBER

PUBLICATION DATE

PUBLICATION TITLE

BE EXACT PIN-POINT WHERE IT IS

PAGE  
NO.

PARA-  
GRAPH

FIGURE  
NO.

TABLE  
NO.

IN THIS SPACE, TELL WHAT IS WRONG  
AND WHAT SHOULD BE DONE ABOUT IT.

PRINTED NAME, GRADE OR TITLE AND TELEPHONE NUMBER

SIGN HERE

